



Allgemeine Sicherheitshinweise
General safety notes



- * Montage / Wartung nur durch Fachkräfte.
- * Bei Instandsetzung / Instandhaltung nur Originalteile verwenden.
- * Werden nachträglich Änderungen an Leuchten vorgenommen, so gilt derjenige als Hersteller, der diese Änderung vornimmt.
- * Der Hersteller übernimmt keine Haftung für Schäden, die durch unsachgemäßen Einsatz entstehen.



- * Installation / maintenance only by skilled personnel.
- * During overhaul / maintenance only use original parts.
- * If any luminaire is subsequently modified, the person responsible for the modification shall be considered the manufacturer.
- * The manufacturer bears no liability for damage caused by inappropriate use or application.



- * Les opérations d'installation et d'entretien doivent être effectuées exclusivement par des personnes qualifiées.
- * Dans le cas d'une remise en état, utiliser uniquement des composants d'origine.
- * Toutes modifications apportées au luminaire se feront sous la responsabilité exclusive de celui qui les effectue.
- * Le fabricant décline toute responsabilité résultant d'un mise en oeuvre inappropriée du produit.



- * El montaje y mantenimiento lo efectuaran únicamente los técnicos especializados.
- * Para reparaciones han de emplearse solo piezas originales de recambio.
- * Reservado el derecho de modificación de dimensiones, pesos y características técnicas, sin previo aviso.
- * El fabricante no asume responsabilidad por modificaciones realizadas por terceros, ni por instalación incorrecta.



- * Montaggio / Manutenzione solo per mezzo di Personale specializzato.
- * Per Riparazione / Manutenzione impiegare solo Parti originali.
- * Il costruttore si riserva il diritto di apportare senza preavviso modifiche di peso, dimensioni e caratteristiche tecniche.
- * Il costruttore non è responsabile per danni derivanti da modifiche realizzate da terzi e da una installazione non corretta.



- * Montagem/Manutenção efectuada unicamente por pessoal técnico especializado.
- * Utilizar somente peças originais do fabricante.
- * O fabricante não se responsabiliza por danos resultantes da inadequada utilização dos materiais.



- * A szerelés / karbantartást csak szakszemélyzet végezheti
- * Üzembehelyezésnél / karbantartásnál csak eredeti alkatrészek használhatók.



- * Τοποθέτηση / Συντήρηση μόνο από ηλεκτρολόγο
- * Κατά την επισκευή / διατήρηση χρησιμοποιείτε γνήσια ανταλλακτικά μόνο



- * Montage / service alleen door vakkundig personeel.
- * Bij inbedrijfstellen / onderhoud alleen originele onderdelen gebruiken.



- * Monteres kun av fagpersonell.
- * Ved feilretting : Bruk kun originaldeler.



- * Montering akötsel endast av fackfolk.
- * Använd bara originaldelar vid igångsättning / underhall.



- * при ремонте применять только те же самые части.
- * Монтаж / обслуживание только специалистами.



- * Montáž a údržba může být prováděna výhradně odbornou pracovní silou.
- * Při údržbě nebo opravě musí být použity jen originální náhradní díly.



- * Montaj ve Bakim sadece yetkili personel tarafından yapılmalıdır.
- * Bakimda sadece orijinal parçalar kullanılmalıdır.

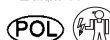

- * Montaż / konserwacja tylko przez fachowy personal.
- * Dla naprawy / bieżącej eksploatacji stosować tylko oryginalne części zamienne.

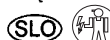

- * Montažo/vzdrževanje lahko izvrši le ustrezno usposobljena oseba.
- * Pri popravilu/vzdrževalnih delih se lahko uporabljajo samo originalni deli.
- * V kolikor se na svetilkah naknadno izvedejo spremembe, se za proizvajalca svetilke smatra tisti, ki je izvedel spremembo.
- * Proizvajalec ne jamči za škodo, ki bi nastala zaradi nepravilne uporabe.



- * Montažo/održavanje mora vršiti odgovarajuće osposobljena osoba.
- * Pri popravku/održavanju koristiti samo originalne dijelove.
- * Ukoliko se na svjetiljkama naknadno vrše promjene, za proizvođača svjetiljke se smatra taj koji je promjene izvršio.
- * Proizvođač ne garantuje za štetu koja bi mogla nastati usled nepravilne upotrebe

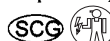

- * Montažo/održavanje može da obavi samo stručno osposobljena osoba.
- * Pri popravljanju/održavanju upotrebljavati samo originalne delove.
- * Ukoliko se na svetilkama naknadno urade izmene, za proizvođača svetilke će se smatrati onaj ko izmene izvrši.
- * Proizvođač ne garantuje za štetu koja bi mogla nastati usled nepravilne upotrebe.

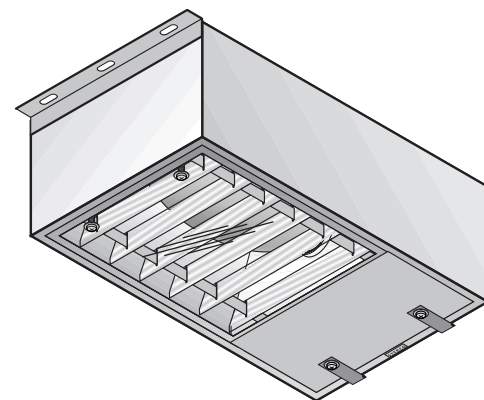

siteco

Siteco Beleuchtungstechnik,
Ohmstraße 50, 83301 Traunreut.
Anrufen: 0 86 69/33-822
Faxen: 0 86 69/33-540
E-Mail: info@siteco.de
Internet: www.siteco.de

Wenn Sie technische Fragen haben:
Hotline: 08669 / 33-844

Siteco Lighting Systems,
Ohmstraße 50, D-83301 Traunreut.
Phone: +49 0 86 69/33-822
Fax: +49 0 86 69/33-540
mail: info@siteco.de
Surf: www.siteco.de

If you have technical questions:
Hotline: +49 8669 / 33-844

Montage- /
Betriebsanleitung
Mounting- /
Operating instruction

Hallenspiegel

Kompakt-Reflektorleuchte IP65
Low-Bay IP65



5NX767....

Bestellnr./Order-number: 97454
copyright Siteco
Änderungen vorbehalten
ab / 21.10.2004

Bitte aufbewahren!
Please keep for future reference!

1

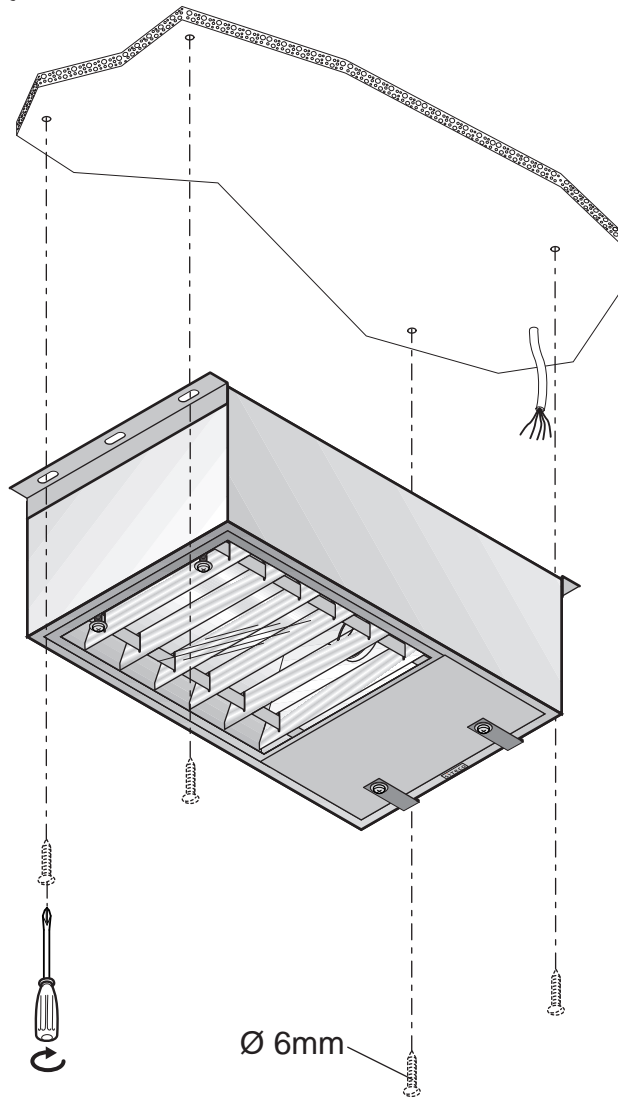
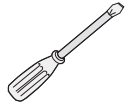

6

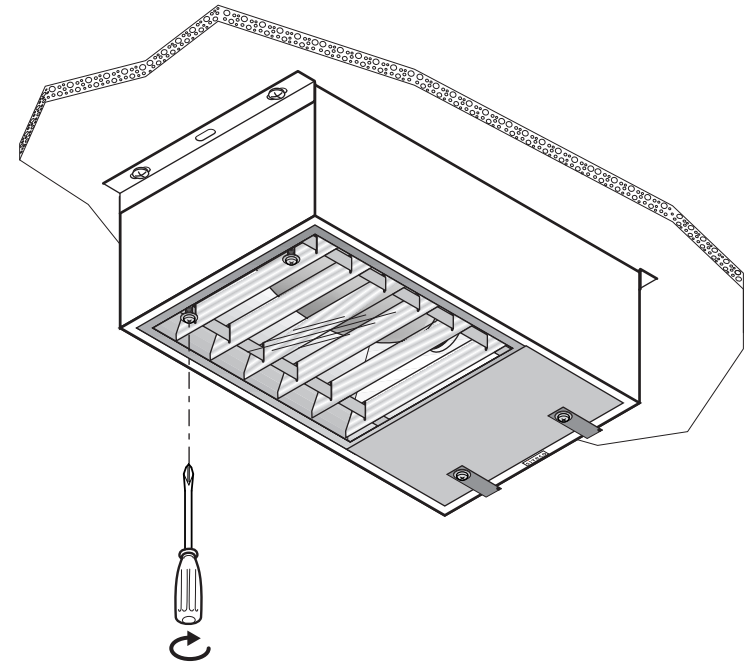
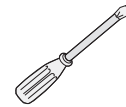

4

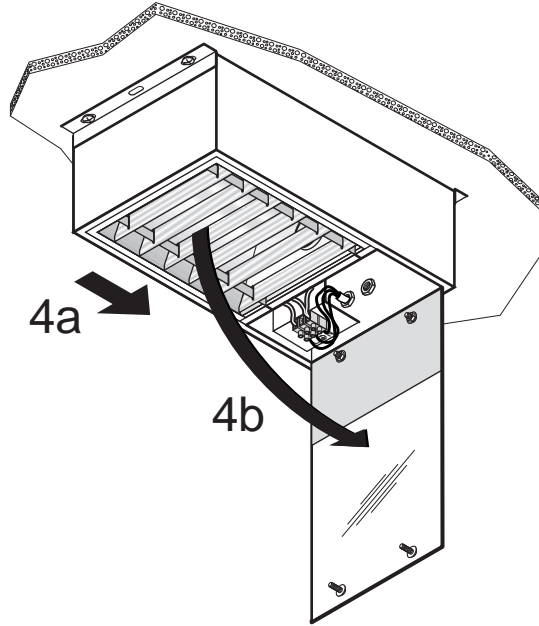

5

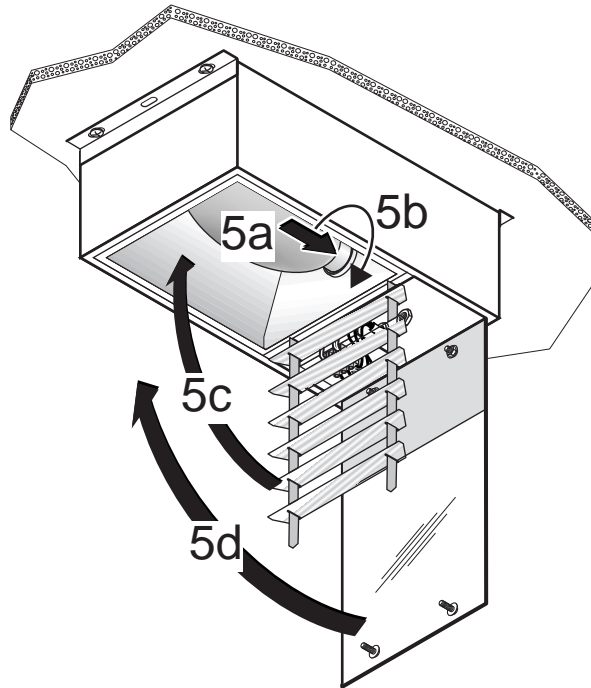

i Abmessungen / dimensions

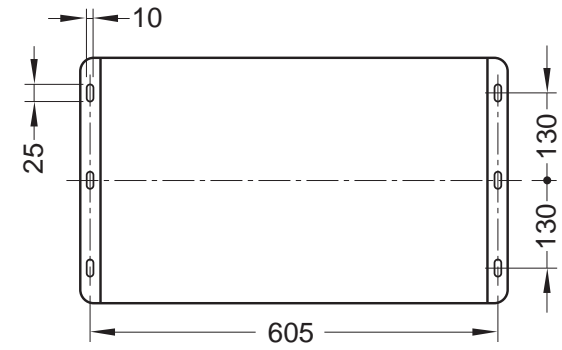
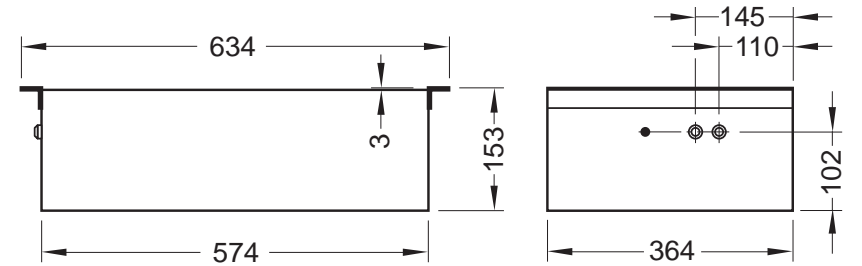
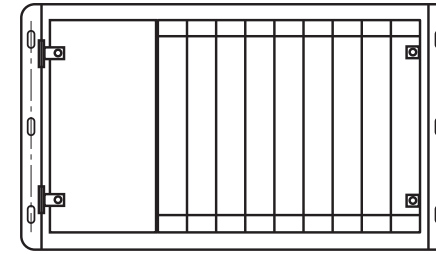

2

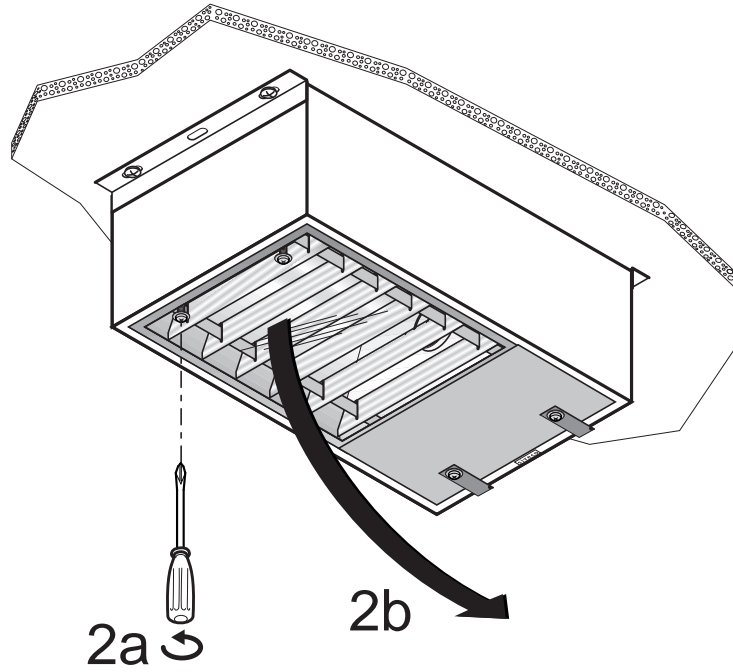

3 

